

772 SERIES

OPEN TOP CSP

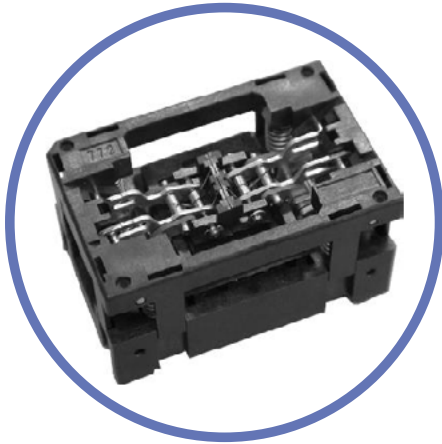

Features

- 0.4mm pitch for large array
- Compression surface mount
- Support up to 34x34 ball matrix
- Z-axis compliant buckling beam, contact provides stable contact performance independent of solder ball height and composition
- Sharpe edge of dual-point contact tip provides high electrical performance, minimizing ball damage
- Staggered fan out footprint for PCB design consideration
- Advanced latching system provide the ability to handle very thin package, limiting package wrap

MATERIALS AND SPECIFICATIONS

Body Materials	PES, PEI, LCP, or Equivalent
Contact Material	Beryllium Copper Alloy
Contact Plating	Gold
Contact Normal Force	13 gram average
Contact Resistance	200~300 mΩ
Capacitance	
Temperature Rating	150°C
Durability	10,000 cycles min.

Pitch e (mm)	Package Size (mm)	Pin Matrix	Max. Pin Count	Ball Dia. (mm)	Ball Height (mm)	Part Number
0.4	6.2 x 12.6	14 x 30	420	0.25	0.17	772-B04420-XXX
	12.6 x 12.6	30 x 30	900	0.23	0.17	772-B04900-XXX
	13.4 x 13.4	32 x 32	1024	0.25	0.17	772-B041024-XXX
	14 x 14	33 x 33	1089	0.25	0.16	772-B041089-XXX



DIMENSIONS AND DIAGRAMS

Dimensions in mm

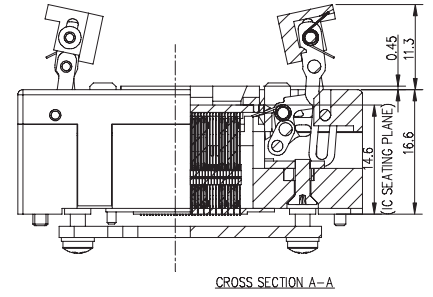
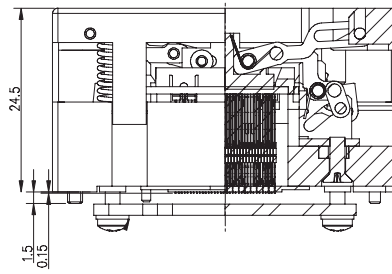
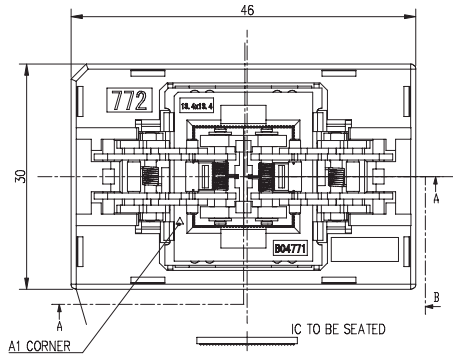

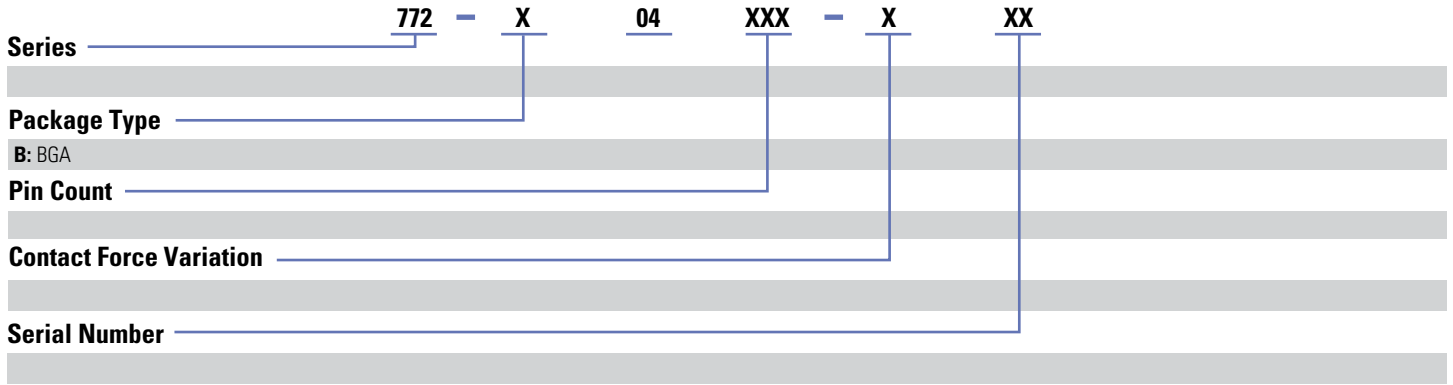

Revised 02/06/18

Sensata Technologies, Inc. ("Sensata") data sheets are solely intended to assist designers ("Buyers") who are developing systems that incorporate Sensata products (also referred to herein as "components"). Buyer understands and agrees that Buyer remains responsible for using its independent analysis, evaluation and judgment in designing Buyer's systems and products. Sensata data sheets have been created using standard laboratory conditions and engineering practices. Sensata has not conducted any testing other than that specifically described in the published documentation for a particular data sheet. Sensata may make corrections, enhancements, improvements and other changes to its data sheets or components without notice.

Buyers are authorized to use Sensata data sheets with the Sensata component(s) identified in each particular data sheet. HOWEVER, NO OTHER LICENSE, EXPRESS OR IMPLIED, BY ESTOPPEL OR OTHERWISE TO ANY OTHER SENSATA INTELLECTUAL PROPERTY RIGHT, AND NO LICENSE TO ANY THIRD PARTY TECHNOLOGY OR INTELLECTUAL PROPERTY RIGHT, IS GRANTED HEREIN. SENSATA DATA SHEETS ARE PROVIDED "AS IS". SENSATA MAKES NO WARRANTIES OR REPRESENTATIONS WITH REGARD TO THE DATA SHEETS OR USE OF THE DATA SHEETS, EXPRESS, IMPLIED OR STATUTORY, INCLUDING ACCURACY OR COMPLETENESS. SENSATA DISCLAIMS ANY WARRANTY OF TITLE AND ANY IMPLIED WARRANTIES OF MERCHANTABILITY, FITNESS FOR A PARTICULAR PURPOSE, QUIET ENJOYMENT, QUIET POSSESSION, AND NON-INFRINGEMENT OF ANY THIRD PARTY INTELLECTUAL PROPERTY RIGHTS WITH REGARD TO SENSATA DATA SHEETS OR USE THEREOF.

All products are sold subject to Sensata's terms and conditions of sale supplied at www.sensata.com SENSATA ASSUMES NO LIABILITY FOR APPLICATIONS ASSISTANCE OR THE DESIGN OF BUYERS' PRODUCTS. BUYER ACKNOWLEDGES AND AGREES THAT IT IS SOLELY RESPONSIBLE FOR COMPLIANCE WITH ALL LEGAL, REGULATORY AND SAFETY-RELATED REQUIREMENTS CONCERNING ITS PRODUCTS, AND ANY USE OF SENSATA COMPONENTS IN ITS APPLICATIONS, NOTWITHSTANDING ANY APPLICATIONS-RELATED INFORMATION OR SUPPORT THAT MAY BE PROVIDED BY SENSATA.

Mailing Address: Sensata Technologies, Inc., 529 Pleasant Street, Attleboro, MA 02703, USA.

CONTACT US

Americas
480.682.6148 or 480.681.6116